

SCU 組合型控制器 SCU Assembly Type Controller

連接馬達與控制器的接頭，於控制器 AC 兩端接上 AC 電源 (請確認電源是否正確)，開關切到 RUN 的位置時 LED 為綠色，此時馬達為運轉狀態，調整控制器上的旋鈕即可控制馬達轉速快慢。註：SCUN 速度顯示組合型控制器使用方法與標準組合型控制器相同。

Connect motor and controller and supply AC power at power at AC two ends of controller AC power. (please check on correct power source). When the switch is turned to RUN position, LED is green. Then the motor is operating. Adjust the knob on the control to control the speed of the motor. Note: Operation of SCUN speed display controller is the same as standard assembly type control.

調速器外觀尺寸圖 Drawing of the Speed Controller

SCU-□

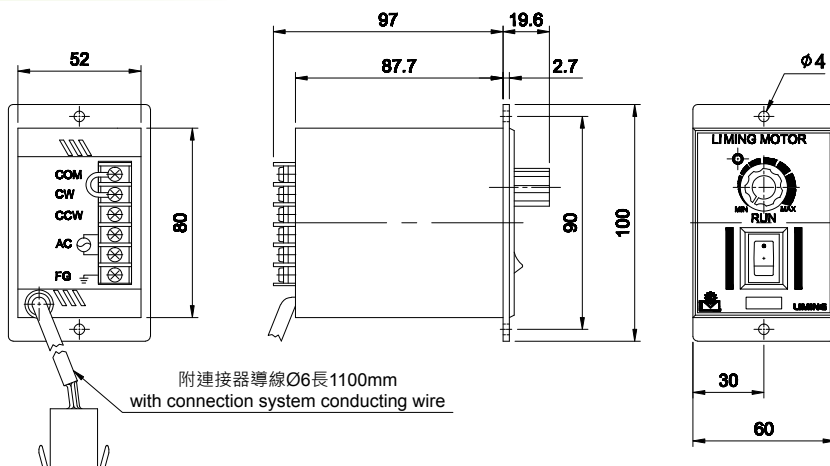

調速器面板安裝加工圖 Installation and Processing Diagram of Speed Control Panel

