

QE Series

Low Profile

2-6 QE Series – Low Profile Linear Guideway, with SynchMotion™ Technology

The development of HIWIN-QE linear guideway is based on a four-row circular-arc contact. The HIWIN-QE series linear guideway with SynchMotion™ Technology offers smooth movement, superior lubrication, quieter operation and longer running life. Therefore the HIWIN-QE linear guideway has broad industrial applicability. In the high-tech industry where high speed, low noise, and reduced dust generation is required, the HIWIN-QE series is interchangeable with the HIWIN-EG series.

2-6-1 Construction

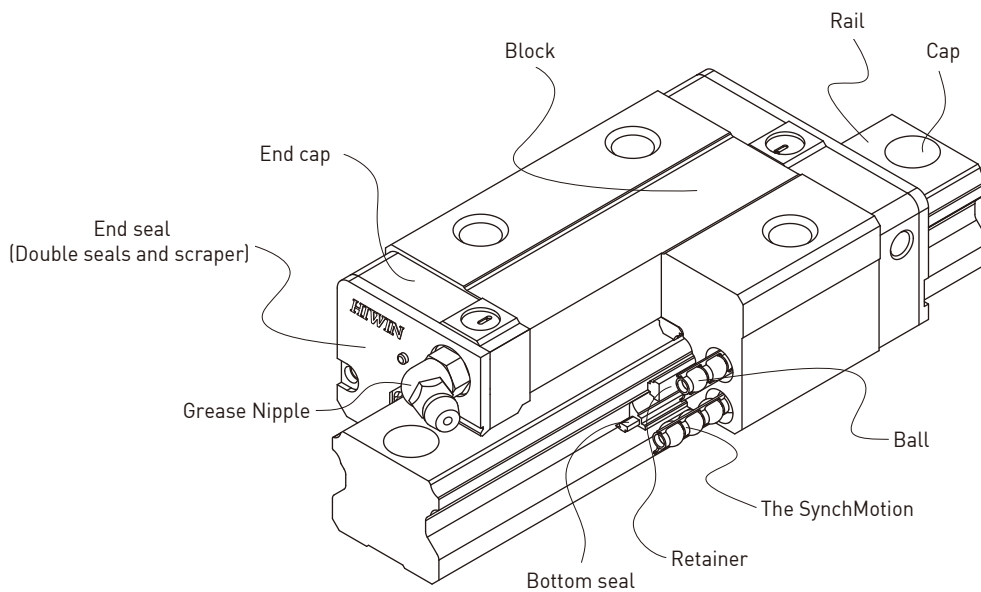

2-6-2 Model Number of QE Series

HIWIN-QE series guideway can be classified into non-interchangeable and interchangeable types. The sizes are identical. The main difference is that the interchangeable blocks and rails can be freely exchanged. Because of dimensional control, the interchangeable type linear guideway is a perfect choice for the client when rails do not need to be paired for an axis. And since the QE and EG share the identical rails, the customer does not need to redesign when choosing the QE series. Therefore the HIWIN-QE linear guideway has increased applicability.

(1) Non-interchangeable type

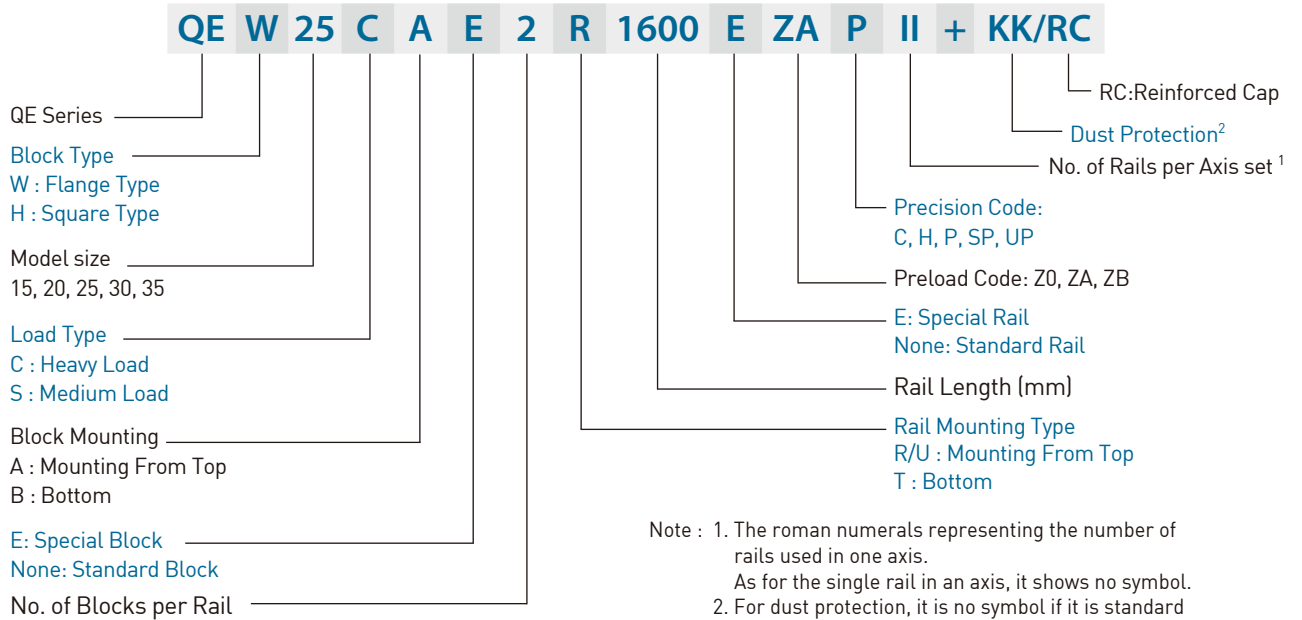

(2) Interchangeable type

○ Model Number of QE Block

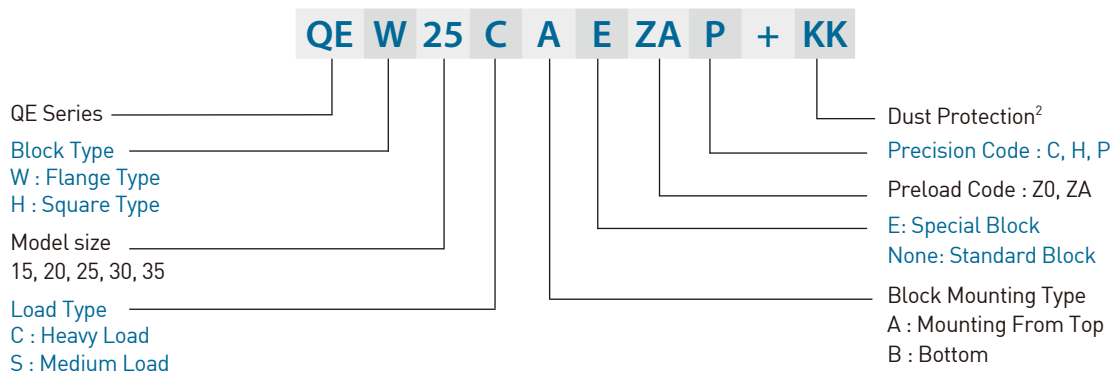

○ Model Number of QE Rail (QE and EG share the identical rails)

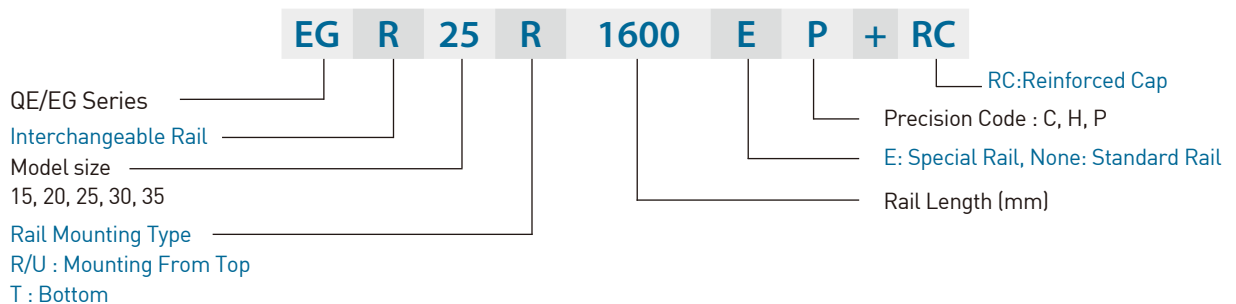

QE Series

Low Profile

2-6-3 Types

(1) Block types

HIWIN offers two types of linear guideways, flange and square types.

Table 2-6-1 Block Type

Type	Model	Shape	Height (mm)	Rail Length (mm)	Main Applications
Square	QEH-SA QEH-CA		24	100	<ul style="list-style-type: none"> ○ Automation devices ○ High-speed transportation equipment ○ Precision measuring equipment ○ Semiconductor manufacturing equipment
			↓	↓	
Flange	QEW-SA QEW-CA		48	4000	
			↓	↓	
			24	100	
			↓	↓	
Flange	QEW-SB QEW-CB		48	4000	
			↓	↓	
			24	100	
			↓	↓	

(2) Rail types

Besides the standard top mounting type, the bottom mounting type is also available.

Table 2-6-2 Rail Types

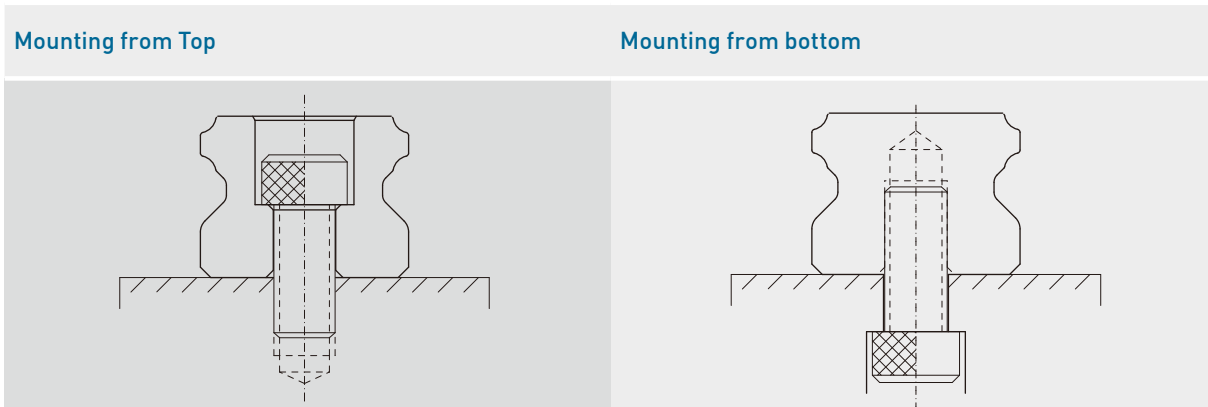

2-6-4 Accuracy

The accuracy of the QE series can be classified into 5 classes: normal(C), high(H), precision(P), super precision(SP), and ultra precision(UP). Choose the class by referencing the accuracy of selected equipment.

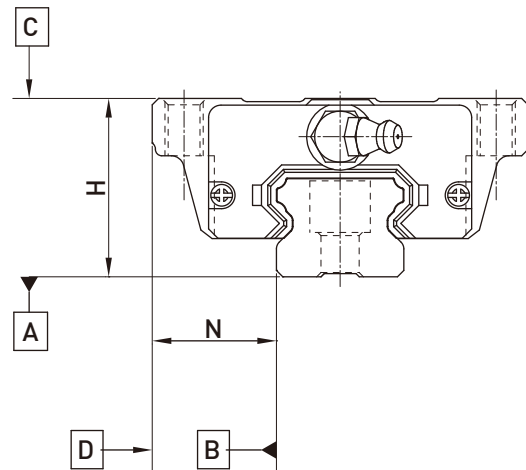

(1) Accuracy of non-interchangeable guideways

Table 2-6-3 Accuracy Standards

Unit: mm

Item	QE - 15, 20				
	Normal (C)	High (H)	Precision (P)	Super Precision (SP)	Ultra Precision (UP)
Dimensional tolerance of height H	± 0.1	± 0.03	0 - 0.03	0 - 0.015	0 - 0.008
Dimensional tolerance of width N	± 0.1	± 0.03	0 - 0.03	0 - 0.015	0 - 0.008
Variation of height H	0.02	0.01	0.006	0.004	0.003
Variation of width N	0.02	0.01	0.006	0.004	0.003
Running parallelism of block surface C to surface A	See Table 2-6-7				
Running parallelism of block surface D to surface B	See Table 2-6-7				

Table 2-6-4 Accuracy Standards

Unit: mm

Item	QE - 25, 30, 35				
	Normal (C)	High (H)	Precision (P)	Super Precision (SP)	Ultra Precision (UP)
Dimensional tolerance of height H	± 0.1	± 0.04	0 - 0.04	0 - 0.02	0 - 0.01
Dimensional tolerance of width N	± 0.1	± 0.04	0 - 0.04	0 - 0.02	0 - 0.01
Variation of height H	0.02	0.015	0.007	0.005	0.003
Variation of width N	0.03	0.015	0.007	0.005	0.003
Running parallelism of block surface C to surface A	See Table 2-6-7				
Running parallelism of block surface D to surface B	See Table 2-6-7				

QE Series

Low Profile

(2) Accuracy of interchangeable guideways

Table 2-6-5 Accuracy Standards

Unit: mm

Item	QE - 15, 20		
Accuracy Classes	Normal (C)	High (H)	Precision (P)
Dimensional tolerance of height H	± 0.1	± 0.03	± 0.015
Dimensional tolerance of width N	± 0.1	± 0.03	± 0.015
Variation of height H	0.02	0.01	0.006
Variation of width N	0.02	0.01	0.006
Running parallelism of block surface C to surface A	See Table 2-6-7		
Running parallelism of block surface D to surface B	See Table 2-6-7		

Table 2-6-6 Accuracy Standards

Unit: mm

Item	QE - 25, 30, 35		
Accuracy Classes	Normal (C)	High (H)	Precision (P)
Dimensional tolerance of height H	± 0.1	± 0.04	± 0.02
Dimensional tolerance of width N	± 0.1	± 0.04	± 0.02
Variation of height H	0.02	0.015	0.007
Variation of width N	0.03	0.015	0.007
Running parallelism of block surface C to surface A	See Table 2-6-7		
Running parallelism of block surface D to surface B	See Table 2-6-7		

(3) Accuracy of running parallelism

Table 2-6-7 Accuracy of Running Parallelism

Rail Length (mm)	Accuracy (μm)				
	C	H	P	SP	UP
~ 100	12	7	3	2	2
100 ~ 200	14	9	4	2	2
200 ~ 300	15	10	5	3	2
300 ~ 500	17	12	6	3	2
500 ~ 700	20	13	7	4	2
700 ~ 900	22	15	8	5	3
900 ~ 1,100	24	16	9	6	3
1,100 ~ 1,500	26	18	11	7	4
1,500 ~ 1,900	28	20	13	8	4
1,900 ~ 2,500	31	22	15	10	5
2,500 ~ 3,100	33	25	18	11	6
3,100 ~ 3,600	36	27	20	14	7
3,600 ~ 4,000	37	28	21	15	7

2-6-5 Preload

(1) Definition

A preload can be applied to each guideway. Generally, a linear motion guideway has a negative clearance between the groove and balls in order to improve stiffness and maintain high precision. The figure shows that adding a preload can improve stiffness of the linear guideway. A preload no greater than ZA would be recommended for model sizes smaller than QE20. This will avoid an over-loaded condition that would affect guideway life.

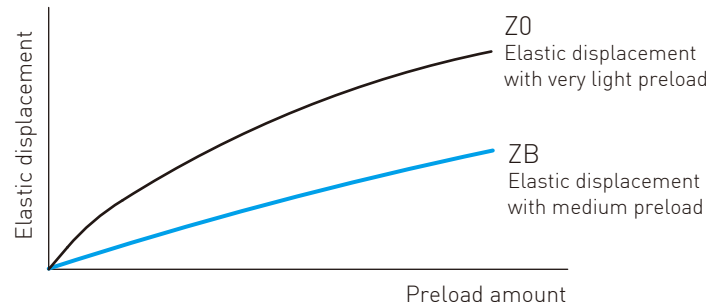

(2) Preload classes

HIWIN offers three standard preloads for various applications and conditions.

Table 2-6-8 Preload Classes

Class	Code	Preload	Condition
Very Light Preload	Z0	0~ 0.02C	Certain load direction, low impact, low precision required
Light Preload	ZA	0.03C~0.05C	low load and high precision required
Medium Preload	ZB	0.06C~ 0.08C	High rigidity required, with vibration and impact

Class	Interchangeable Guideway	Non-Interchangeable Guideway
Preload classes	Z0, ZA	Z0, ZA, ZB

Note: The "C" in the preload column denotes basic dynamic load rating.

2-6-6 Dust Protection Equipment

(1) Codes of equipment

If the following equipment is needed, please indicate the code followed by the model number.

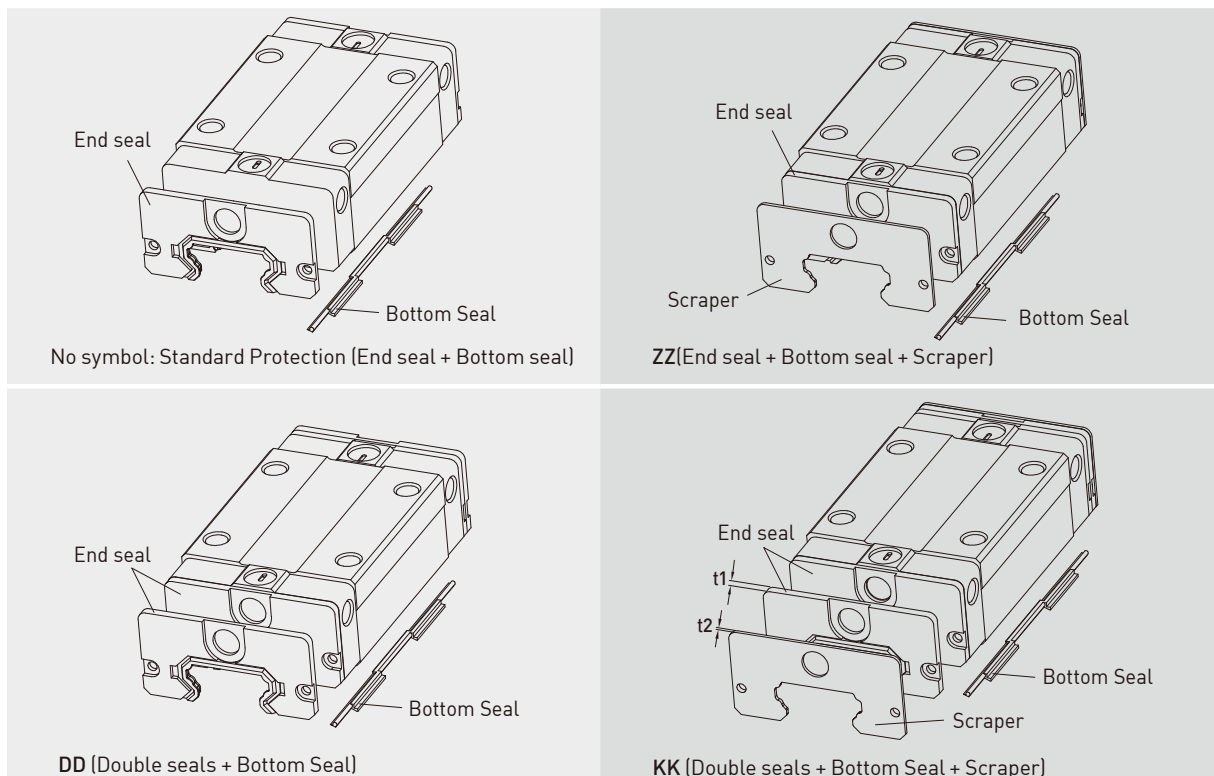

QE Series

Low Profile

(2) End seal and bottom seal

To prevent life reduction caused by iron chips or dust entering the block.

(3) Double seals

Removes foreign matter from the rail preventing contaminants from entering the block.

Table 2-6-9 Dimensions of end seal

Size	Thickness (t1) (mm)	Size	Thickness (t1) (mm)
QE15 ES	2	QE30 ES	2.5
QE20 ES	2	QE35 ES	2
QE25 ES	2.5		

(4) Scraper

Clears larger contaminants, such as weld spatter and metal cuttings, from the rail. Metal scraper protects end seals from excessive damage.

Table 2-6-10 Dimensions of Scraper

Size	Thickness (t2) (mm)
QE15 SC	1
QE20 SC	1
QE25 SC	1
QE30 SC	1
QE35 SC	1.5

(5) Dimensions of block equipped with the dustproof parts

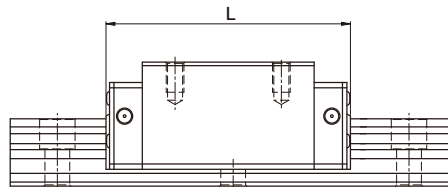

Table 2-6-11 Overall block length

unit: mm

Size	Overall block length (L)			
	SS	ZZ	DD	KK
QE15S	40.1 (42.9)	42.1 (46.5)	44.1 (46.9)	46.1 (50.5)
QE15C	56.8 (59.6)	58.8 (63.2)	60.8 (63.6)	62.8 (67.2)
QE20S	50.0 (54.0)	52.0 (58.0)	54.0 (58.0)	56.0 (62.0)
QE20C	69.1 (73.1)	71.1 (77.1)	73.1 (77.1)	75.1 (81.1)
QE25S	60.1 (63.5)	62.1 (68.1)	65.1 (68.5)	67.1 (73.1)
QE25C	83.6 (87.0)	85.6 (91.6)	88.6 (92.0)	90.6 (96.6)
QE30S	67.5 (71.3)	69.5 (75.5)	72.5 (76.3)	74.5 (80.5)
QE30C	96.1 (99.9)	98.1 (104.1)	101.1 (104.9)	103.1 (109.1)
QE35S	76.0 (80.0)	79.0 (84.0)	80.0 (84.0)	83.0 (88.0)
QE35C	108.0 (112)	111.0 (116.0)	112.0 (116.0)	115.0 (120.0)

Note : The marking of "()" denotes the maximum block length with screws, lips of end seals, etc.

2-6-7 Friction

The maximum value of resistance per end seal are as shown in the table.

Table 2-6-12 Seal Resistance

Size	Resistance N (kgf)
QE15	1.08 (0.11)
QE20	1.37 (0.14)
QE25	1.67 (0.17)
QE30	2.06 (0.21)
QE35	2.26 (0.23)

Note: 1kgf=9.81N

2-6-8 Mounting Surface Accuracy Tolerance

Because of the circular-arc contact design, the QE linear guideway can withstand surface-error installation and deliver smooth linear motion. When the mounting surface meets the accuracy requirements of the installation, the high accuracy and rigidity of the guideway will be obtained without any difficulty. For faster installation and smoother movement, HIWIN offers a preload with normal clearance because of its ability to absorb higher deviations in mounting surface inaccuracies.

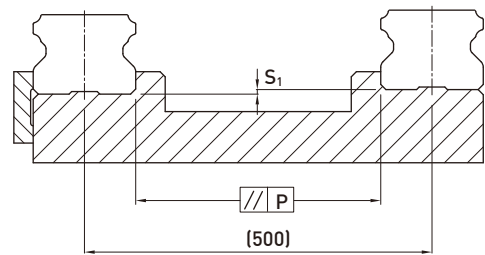

Table 2-6-13 Max. Parallelism Tolerance (P)

unit: μm

Size	Preload classes		
	Z0	ZA	ZB
QE15	25	18	-
QE20	25	20	18
QE25	30	22	20
QE30	40	30	27
QE35	50	35	30

Table 2-6-14 Max. Tolerance of Reference Surface Height (S_1)

unit: μm

Size	Preload classes		
	Z0	ZA	ZB
QE15	130	85	-
QE20	130	85	50
QE25	130	85	70
QE30	170	110	90
QE35	210	150	120

Note: The allowable value is proportional to the distance between the axes.

QE Series

Low Profile

2-6-9 Cautions for Installation

(1) Shoulder heights and chamfers

Improper shoulder heights and chamfers of mounting surfaces will cause deviations in accuracy and rail or block interference with the chamfered part.

When recommended shoulder heights and chamfers are used, problems with installation accuracy should be eliminated.

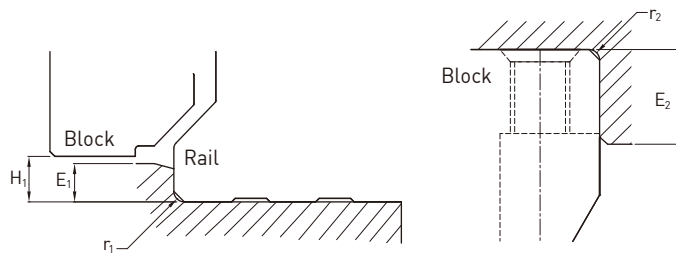

Table 2-6-15 Shoulder Heights and Chamfers

unit: mm

Size	Max. radius of fillets r_1 (mm)	Max. radius of fillets r_2 (mm)	Shoulder height of the rail E_1 (mm)	Shoulder height of the block E_2 (mm)	Clearance under block H_1 (mm)
QE15	0.5	0.5	2.7	5.0	4.0
QE20	0.5	0.5	5.0	7.0	6.0
QE25	1.0	1.0	5.0	7.5	6.2
QE30	1.0	1.0	7.0	7.0	10.0
QE35	1.0	1.5	7.5	9.5	11.0

(2) Tightening Torque of Bolts for Installation

Improperly tightened mounting bolts will seriously affect the accuracy of linear guide installations. The following tightening torques for different sizes of bolts are recommended.

Table 2-6-16 Tightening Torque

Size	Bolt size	Torque N-cm(kgf-cm)		
		Iron	Casting	Aluminum
QE15	M3×0.5P×16L	186 (19)	127 (13)	98(10)
QE20	M5×0.8P×16L	883 (90)	588 (60)	441 (45)
QE25	M6×1P×20L	1373 (140)	921 (94)	686 (70)
QE30	M6×1P×25L	1373 (140)	921 (94)	686 (70)
QE35	M8×1.25P×25L	3041 (310)	2010 (205)	1470 (150)

Note: 1 kgf = 9.81 N

2-6-10 Dimensions for HIWIN QE Series

(1) QEH-CA / QEH-SA

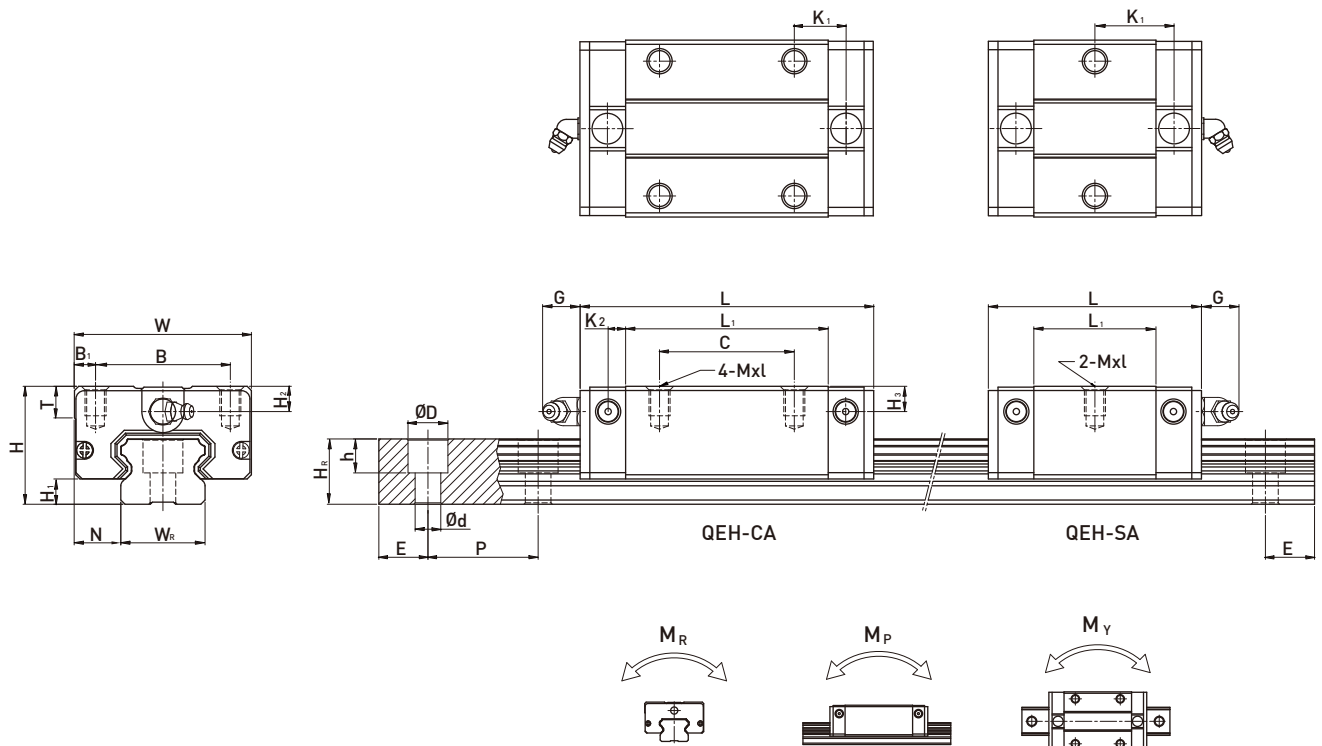

Model No.	Dimensions of Assembly (mm)			Dimensions of Block (mm)										Dimensions of Rail (mm)					Mounting Bolt for Rail (mm)	Basic Dynamic Load Rating C(kN)	Basic Static Load Rating C ₀ (kN)	Static Rated Moment			Weight						
	H	H ₁	N	W	B	B ₁	C	L ₁	L	K ₁	K ₂	G	Mxl	T	H ₂	H ₃	W _R	H _R				D	h	d	P	E	M _R (kN-m)	M _P (kN-m)	M _Y (kN-m)	Block (kg)	Rail (kg/m)
QEH15SA	24	4	9.5	34	26	4	-	23.1	40.1	14.8	3.5	5.7	M4x6	6	5.5	6	15	12.5	6	4.5	3.5	60	20	M3x16	8.56	8.79	0.07	0.03	0.03	0.09	1.25
QEH15CA							26	39.8	56.8	10.15																					
QEH20SA	28	6	11	42	32	5	-	29	50	18.75	4.15	12	M5x7	7.5	6	6.5	20	15.5	9.5	8.5	6	60	20	M5x16	11.57	12.18	0.13	0.05	0.05	0.15	2.08
QEH20CA							32	48.1	69.1	12.3																					
QEH25SA	33	6.2	12.5	48	35	6.5	-	35.5	60.1	21.9	5	12	M6x9	8	8	8	23	18	11	9	7	60	20	M6x20	18.24	18.90	0.22	0.10	0.10	0.24	2.67
QEH25CA							35	59	83.6	16.15																					
QEH30SA	42	10	16	60	40	10	-	41.5	67.5	25.75	6	12	M8x12	9	8	9	28	23	11	9	7	80	20	M6x25	26.27	27.82	0.40	0.18	0.18	0.44	4.35
QEH30CA							40	70.1	96.1	20.05																					
QEH35SA	48	11	18	70	50	10	-	51	76	30.3	6.25	12	M8x12	10	8.5	8.5	34	27.5	14	12	9	80	20	M8x25	36.39	36.43	0.61	0.33	0.33	0.77	6.14
QEH35CA							50	83	108	21.3																					

Note : 1 kgf = 9.81 N

QE Series

Low Profile

(2) QEW-CA / QEW-SA

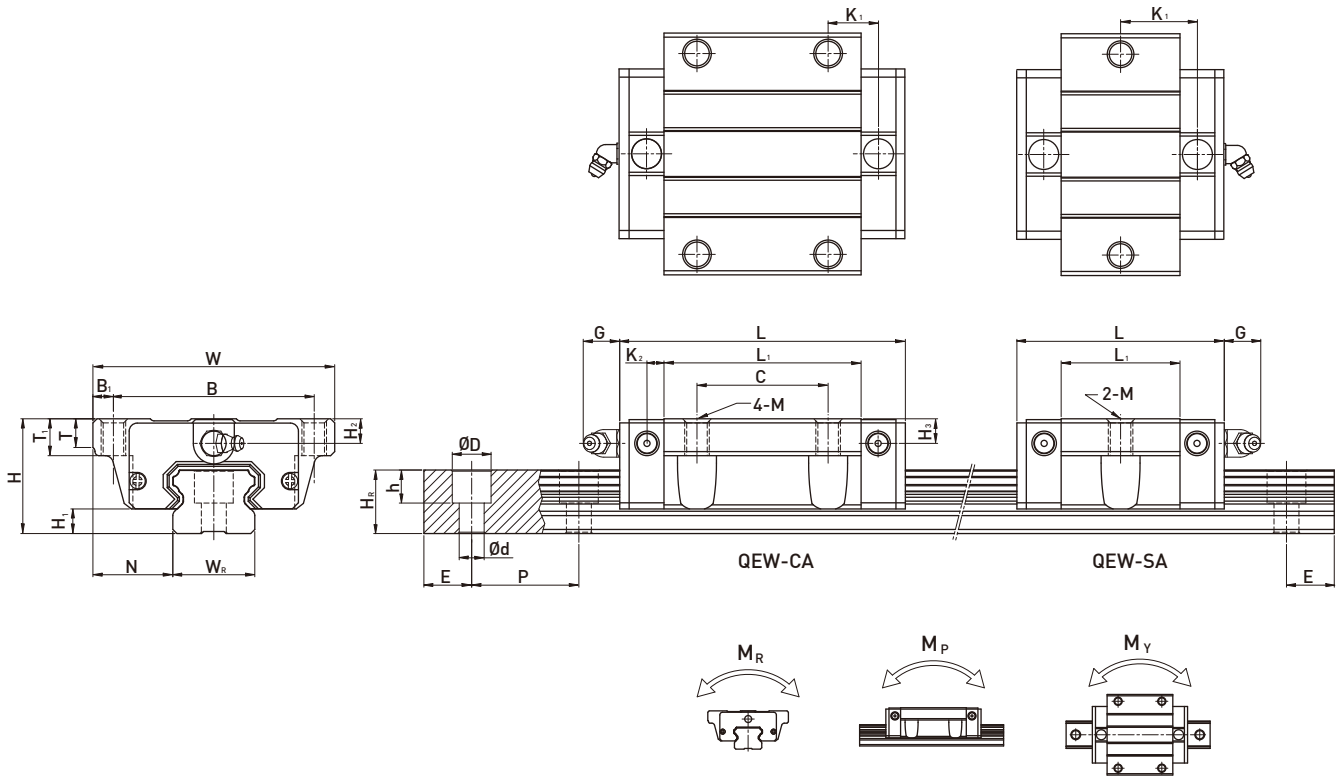

Model No.	Dimensions of Assembly (mm)		Dimensions of Block (mm)													Dimensions of Rail (mm)						Mounting Bolt for Rail (mm)	Basic Dynamic Load Rating C(kN)	Basic Static Load Rating C ₀ (kN)	Static Rated Moment			Weight					
	H	H ₁	N	W	B	B ₁	C	L ₁	L	K ₁	K ₂	G	M	T	T ₁	H ₂	H ₃	W _R	H _R	D	h				d	P	E	M _R	M _P	M _Y	Block	Rail	
	mm	mm	mm	mm	mm	mm	mm	mm	mm	mm	mm	mm	mm	mm	mm	mm	mm	mm	mm	mm	mm				mm	mm	mm	mm	kN-m	kN-m	kN-m	kg	kg/m
QEW15SA	24	4	18.5	52	41	5.5	-	23.1	40.1	14.8	-	3.5	5.7	M5	5	7	5.5	6	15	12.5	6	4.5	3.5	60	20	M3×16	8.56	8.79	0.07	0.03	0.03	0.12	1.25
QEW15CA							26	39.8	56.8	10.15																							
QEW20SA	28	6	19.5	59	49	5	-	29	50	18.75	-	4.15	12	M6	7	9	6	6.5	20	15.5	9.5	8.5	6	60	20	M5×16	11.57	12.18	0.13	0.05	0.05	0.19	2.08
QEW20CA							32	48.1	69.1	12.3																							
QEW25SA	33	6.2	25	73	60	6.5	-	35.5	60.1	21.9	-	5	12	M8	7.5	10	8	8	23	18	11	9	7	60	20	M6×20	18.24	18.90	0.22	0.10	0.10	0.34	2.67
QEW25CA							35	59	83.6	16.15																							
QEW30SA	42	10	31	90	72	9	-	41.5	67.5	25.75	-	6	12	M10	7	10	8	9	28	23	11	9	7	80	20	M6×25	26.27	27.82	0.40	0.18	0.18	0.61	4.35
QEW30CA							40	70.1	96.1	20.05																							
QEW35SA	48	11	33	100	82	9	-	51	76	30.3	-	6.25	12	M10	10	13	8.5	8.5	34	27.5	14	12	9	80	20	M8×25	36.39	36.43	0.61	0.33	0.33	0.77	6.14
QEW35CA							50	83	108	21.3																							

Note : 1 kgf = 9.81 N

(3) QEW-CB / QEW-SB

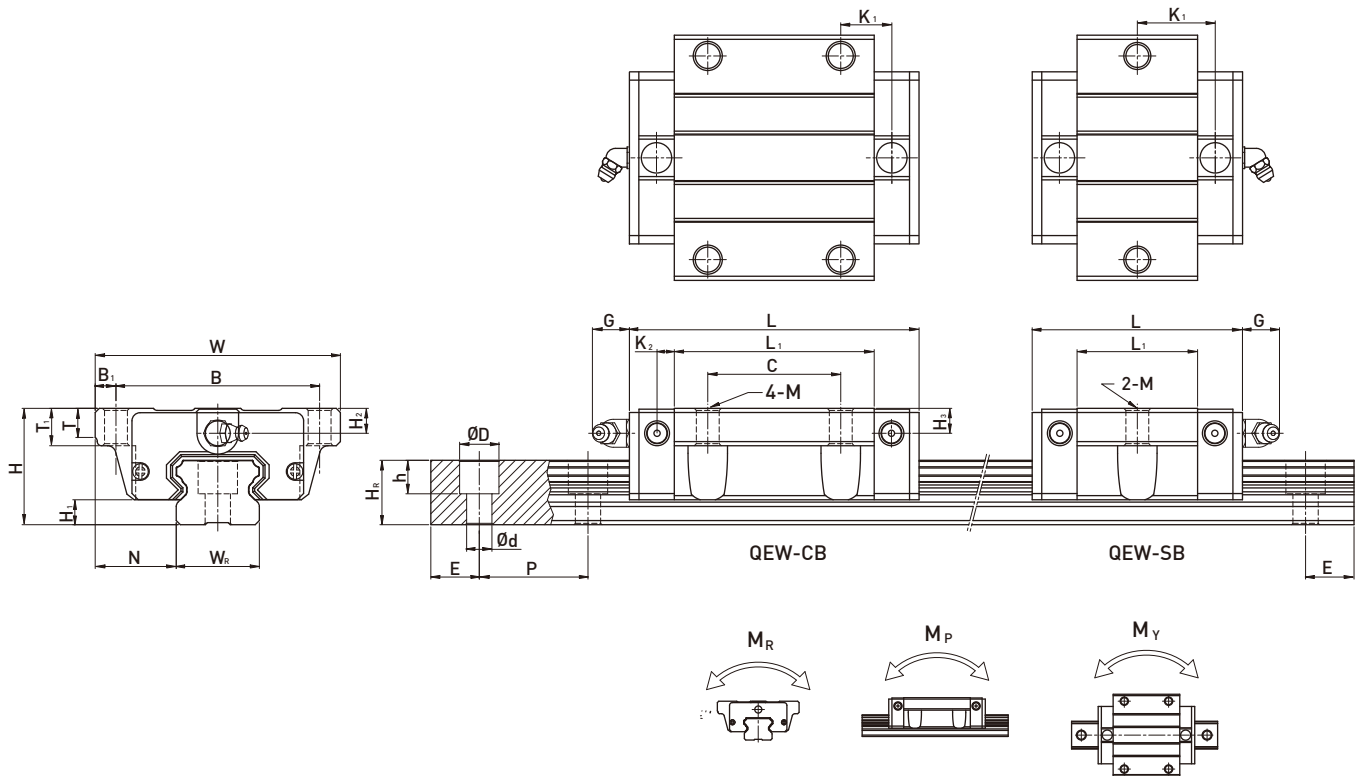

Model No.	Dimensions of Assembly (mm)							Dimensions of Block (mm)										Dimensions of Rail (mm)					Mounting Bolt for Rail (mm)	Basic Dynamic Load Rating C (kN)	Basic Static Load Rating C ₀ (kN)	Static Rated Moment			Weight			
	H	H ₁	N	W	B	B ₁	C	L ₁	L	K ₁	K ₂	G	M	T	T ₁	H ₂	H ₃	W _R	H _R	D	h	d				P	E	M _R	M _P	M _Y	Block	Rail
	mm	mm	mm	mm	mm	mm	mm	mm	mm	mm	mm	mm	mm	mm	mm	mm	mm	mm	mm	mm	mm	mm				mm	mm	mm	kN-m	kN-m	kN-m	kg
QEW15SB	24	4	18.5	52	41	5.5	-	23.1	40.1	14.8	3.5	5.7	Ø4.5	5	7	5.5	6	15	12.5	6	4.5	3.5	60	20	M3x16	8.56	8.79	0.07	0.03	0.03	0.12	1.25
QEW15CB							26	39.8	56.8	10.15																12.53	15.28	0.12	0.09	0.09	0.21	
QEW20SB	28	6	19.5	59	49	5	-	29	50	18.75	4.15	12	Ø5.5	7	9	6	6.5	20	15.5	9.5	8.5	6	60	20	M5x16	11.57	12.18	0.13	0.05	0.05	0.19	2.08
QEW20CB							32	48.1	69.1	12.3																16.50	20.21	0.21	0.15	0.15	0.31	
QEW25SB	33	6.2	25	73	60	6.5	-	35.5	60.1	21.9	5	12	Ø7	7.5	10	8	8	23	18	11	9	7	60	20	M6x20	18.24	18.90	0.22	0.10	0.10	0.34	2.67
QEW25CB							35	59	83.6	16.15																26.03	31.49	0.37	0.29	0.29	0.58	
QEW30SB	42	10	31	90	72	9	-	41.5	67.5	25.75	6	12	Ø9	7	10	8	9	28	23	11	9	7	80	20	M6x25	26.27	27.82	0.40	0.18	0.18	0.61	4.35
QEW30CB							40	70.1	96.1	20.05																37.92	46.63	0.67	0.51	0.51	1.03	
QEW35SB	48	11	33	100	82	9	-	51	76	30.3	6.25	12	Ø9	10	13	8.5	8.5	34	27.5	14	12	9	80	20	M8x25	36.39	36.43	0.61	0.33	0.33	0.77	6.14
QEW35CB							50	83	108	21.3																51.18	59.28	1.00	0.75	0.75	1.19	

Note : 1 kgf = 9.81 N