

FL 型凸爪式弹性联轴器 FL Jaw Flexible Couplings

概述

1. 适用于所有类型的机械和液压转动；
2. 体积小，传递力矩大；
3. 轴向插入，易安装，免维护；
4. 能平衡轴的轴向、径向和角度的相对位移；
5. 内孔尺寸 d 可根据顾客要求制作；
6. 适用温度为 $-40^{\circ}\text{C} \sim +100^{\circ}\text{C}$ ，最高瞬时温度可达 120°C 。



Summary

1. Applicable to all types of machinery and hydraulics.
2. Small volume and large transmitted torque.
3. To be plugged in axially, easy assembly, maintenance-free.
4. Balancing axial, radial and angular misalignment.
5. Dimensions of bore d available on customer's request.
6. Applicable from -40°C to $+100^{\circ}\text{C}$, temperature peaks up to 120°C .

型号及表示方法 Type & Expressions

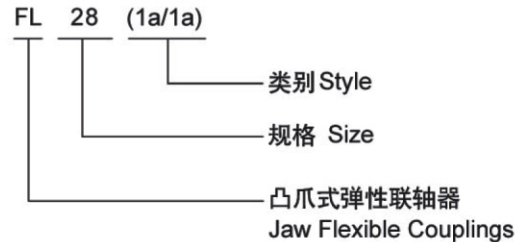

性能参数表 Performance parameters

型号 Type	弹性体 Polyurethane Spider	许用转速 Max speed r/min	额定转矩 Rated torque N·m	最大转矩 Max torque N·m	许用扭转角度 Max torsion angle
FL9	92sh A(黄色)	28000	1.8	3.5	6.4°
FL14		19000	7.5	15	
FL19		14000	10	20	
FL24		10600	35	70	3.2°
FL28		8500	95	190	
FL38		7100	190	380	
FL42		6000	265	530	
FL48		5600	310	620	
FL55		4750	410	820	
FL65		4250	625	1250	
FL75		3550	1280	2560	
FL90		2800	2400	4800	

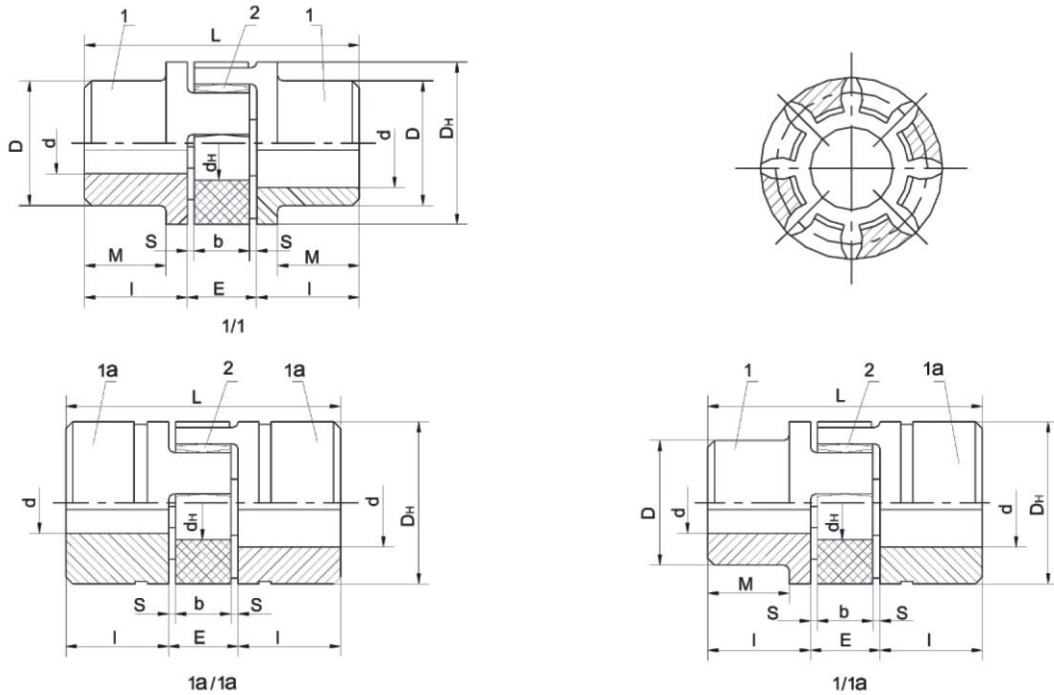

型号 Type	类别 Style	预留孔 Prebored	成品孔径 Finish bores		尺寸 Dimensions								
			d_{min}	d_{max}	I	E	S	b	L	M	D_H	D	d_H
铝合金 Aluminium Diecasting (Al-D)													
FL9	1a		4	9	10	10	1.0	8	30		20		6
FL14	1a		4	16	11	13	1.5	10	35		30		10
FL19	1		6	19	25	16	2.0	12	66	20	40	32	18
	1a		6	24									
钢 Steel													
FL19	1a		6	24	25	16	2.0	12	66		40		18
FL24	1a		8	28	30	18	2.0	14	78		55		27
FL28	1a		10	38	35	20	2.5	15	90		65		30
FL38	1	11	12	38	45	24	3	18	114	37	80	66	38
	1a			12									
FL42	1	13	14	42	50	26	3	20	126	40	95	75	46
	1a			14									
FL48	1	14	15	48	56	28	3.5	21	140	45	105	85	51
	1a			15									
FL55	1	18	20	55	65	30	4	22	160	52	120	98	60
	1a			20									
FL65	1	20	22	65	75	35	4.5	26	185	61	135	115	68
	1a			22									
FL75	1	28	30	75	85	40	5	30	210	69	160	135	80
	1a			30									
FL90	1	38	40	90	100	45	5.5	34	245	81	200	160	100
	1a			40									